

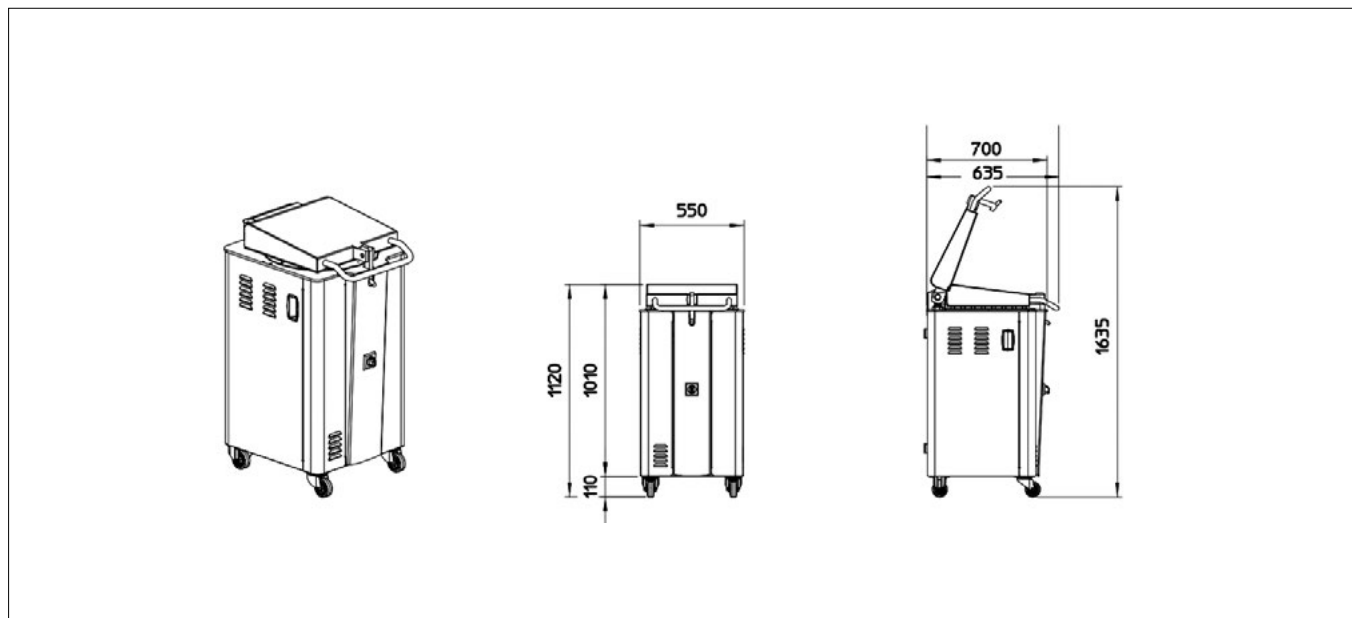



ESAGONAL DIVIDERS



Machine suitable to divide dough used in bakeries and pastry workshops. Steel stove painted structure. Inox version available. Reduced dimensions. Stainless steel AISI 304 bowl and knives. Food nylon hexagons. Automatic switching off hydraulic unit noiseless and reliable. Push-button for knives cleaning. Complete hydraulic working. In DEA automatic version working cycle: pressing, cutting and cover opening completely automatic. In DES semi automatic one the working cycle: pressing and cutting by joystick, manual cover opening. For both versions available 3 models at 37 divisions. Usable as a press.



	Pieces	Weight range	Capacity	Mould	Basket depth	Weight	Power
	n°	g	kg	mm	mm	kg	kW
DEA DES 3757	37	30-130	4,8	 57	70	190	0,75
DEA DES 3760	37	35-135	5	 60	70	190	0,75
DEA DES 3763	37	40-160	6	 63	70	190	0,75